

Therefore, it is not unlikely that many of the spectral features observed in the RR spectrum of monomeric BChl⁺ will be similar to, if not identical with, those of the oxidized special pair BChl in the RC (the 1597-cm⁻¹ band has been observed in both cases³⁹). Further experiments are planned, by using model systems and RC preparations, to examine in more detail the effects of BChl-BChl interactions on the RR spectrum of the cation radical.

Acknowledgment. The authors wish to thank J. D. Petke, G.

M. Maggiora, L. L. Shipman, and R. E. Christoffersen for providing their manuscripts to us prior to publication and Earl Klugman of PARC for the loan of the OMA-2 system. The support of this research by the National Institutes of Health under Grant GM27498-01 and the National Science Foundation under Grant CHE 789-00877 is gratefully acknowledged. In addition, T.M.C. acknowledges support from an NIH Postdoctoral Fellowship and K.D.P. acknowledges support from Eastman Kodak for the 1979-1980 academic year.

Pulsed IR Laser Study of Half-Chair to Boat Interconversion of 2,3-Dihydropyran¹

Dana Garcia and Ernest Grunwald*

Contribution from the Chemistry Department, Brandeis University, Waltham, Massachusetts 02254. Received April 29, 1980

Abstract: At 298 K 2,3-dihydropyran exists largely in the half-chair conformation. Pulsed laser irradiation of the vapor at 1072 cm⁻¹, in the CH₂-O stretching band, produced *T* jumps to >1400 K. Kinetic UV spectroscopy detected a high-temperature absorption, assignable to the boat form, with $\lambda_{\max} = 237$ nm and ϵ_{\max} (extrapolated to 0 K) = 2.30×10^3 M⁻¹ cm⁻¹. Half-chair to boat interconversion, studied at 600-1100 K, gave $\ln K = -1828/T$ and $\Delta E^\circ = 15.2$ kJ/mol. Relaxation times for interconversion were <50 ns. The phenomenology of IR absorption and of the relatively slow retro-Diels-Alder reaction, which occurs at high *E*_{abs}, is also reported.

Irradiation of gases at pressures above ~5 torr with megawatt IR laser pulses at wavelengths of strong absorption can lead to temperature (*T*) jumps of over 1000 K on time scales of 4 μ s or less. If conditions are controlled so that IR absorption is sufficiently uniform, the *T* jump is followed by a quiescent period of at least a few microseconds during which the temperature of the irradiated volume can be known.² In this paper we use IR laser *T* jumps to study equilibrium and reaction dynamics for the half-chair to boat interconversion of 2,3-dihydropyran (eq 1).

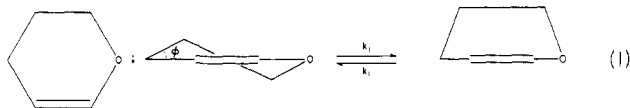

At room temperature, the dominant form of DHP is the half-chair, as indicated by infrared,³ Raman,⁴ microwave,⁵ and NMR⁶ spectra. The absence of microwave absorption assignable to the boat form indicates that the proportion of the latter is $\leq 0.25\%$ (the detection limit)⁵ and that $\Delta G^\circ \geq 15$ kJ at 298 K. The angle of twist ϕ (eq 1) in the half-chair form is 27°, based on microwave data.⁵

Infrared and Raman spectra in the ring-bending and ring-twisting region have been fitted successfully by assuming an effective C₂ molecular symmetry.^{3,4} The potential function giving best fit to the spectral data indicates a half-chair minimum with

$\phi = 23^\circ$. Extrapolation of the potential function indicates a second minimum corresponding to the boat form and an intervening barrier of 30 ± 2 kJ/mol.

Low-temperature NMR data yield kinetic constants for the interconversion of the mirror-image conformations of the half-chair form (eq 2).⁶ The data are consistent with $k_2 = 10^{13} \exp(-E_{\text{act}}/RT)$; E_{act} is 27.6 ± 1.2 kJ/mol, in agreement with the barrier based on IR and Raman data.

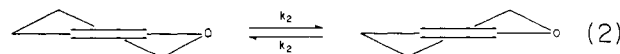

The ultraviolet absorption spectrum of the half-chair isomer in ethanol at room temperature shows end-absorption only.⁷ The vacuum-UV spectrum of the gas shows a longest wavelength peak at 224 nm.⁸ Our measurements for the gas at room temperature show a weak shoulder at 224 nm, with molar extinction coefficient $\epsilon \approx 400$ M⁻¹ cm⁻¹, and negligible absorption above 230 nm.

Observations Consequent to IR Irradiation. An 8-35-torr sample of 2,3-dihydropyran (DHP) was irradiated at 1072 cm⁻¹, near the peak of the CH₂-O stretch absorption band. The following were measured: absorbed energy per mole (*E*_{abs}) of DHP, stable reaction products (if any), and transient UV absorption.

When room-temperature DHP (i.e., the half-chair isomer) absorbs at least 20 kJ/mol from a pulsed IR laser, a transient UV absorption appears with band maximum at 237 nm. For reasons given later, it is assigned to the boat form. Typical results for optical transmission vs. time are shown in Figure 1. Three stages of behavior for the IR excited gas are illustrated. The left-hand panel shows the result of the laser-induced *T* jump. A well-defined plateau is reached after 2 μ s, and this quiescent state persists for several microseconds. Somewhat later, in the middle panel, transmission vs. time becomes oscillatory owing to acoustic waves and mixing. These effects eventually subside and the right-hand panel shows the gas cooling back to room temperature.

(7) Srinivasan, R. *J. Org. Chem.* 1970 35, 786.

(8) Planckaert, A. A.; Doucet, J.; Sandorty, C. *J. Chem. Phys.* 1974, 60, 4846.

(1) (a) Work supported in part by a grant from the National Science Foundation and a grant of equipment from the Edith C. Blum Foundation. (b) Based on the Ph.D. Thesis of D.G., Brandeis University, 1980, where further details are published.

(2) Grunwald, E.; Lonsetta, C. M.; Popok, S. *J. Am. Chem. Soc.* 1979, 101, 5062.

(3) Lord, R. C.; Rounds, T. C.; Ueda, T. *J. Chem. Phys.* 1972, 57, 2572. The authors thank Professor R. C. Lord for a helpful discussion.

(4) Durig, J. R.; Carter, R. O.; Carreira, L. A. *J. Chem. Phys.* 1974, 60, 3098.

(5) Williams, V. E. Ph.D. Thesis, University College of North Wales, Bangor, U.K., 1969. Williams, V. E.; Sheridan, J., private communication, July 1979.

(6) Bushweller, C. H.; O'Neil, J. W. *Tetrahedron Lett.* 1969, 53, 4713.

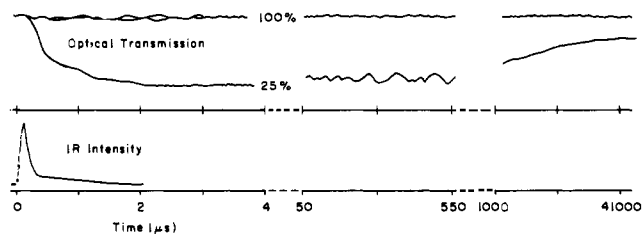

Figure 1. Upper panels: optical transmission vs. time at 237 nm in three similar but independent experiments recorded on different time scales; DHP = 29 torr (298 K); $E_{\text{abs}} = 101$ kJ/mol; $\theta_p = 900$ K; 100% transmission is measured before and after IR irradiation. Lower panel: IR intensity profile.

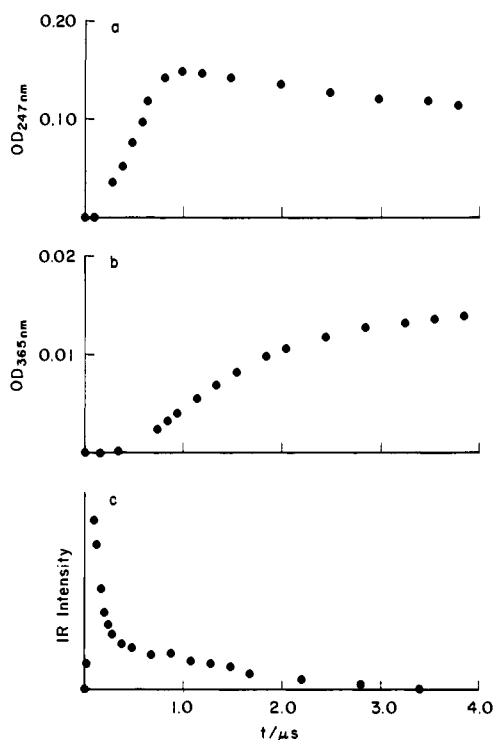
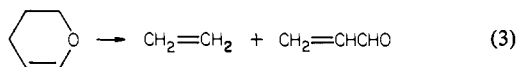

Figure 2. Optical density and pulse intensity vs. time: (a) 18.8 torr (298 K) of DHP, $E_{\text{abs}} = 250$ kJ/mol, 247 nm; (b) 18.0 torr (298 K) of DHP, $E_{\text{abs}} = 260$ kJ/mol, 365 nm; (c) IR intensity profile for a and b, in arbitrary units. Optical density in (a) is due to transient species (boat form of DHP). Note the decrease after 1 μ s. Optical density in (b) is due to acrolein.

It has been reported that DHP undergoes laser-induced retro-Diels-Alder reaction (3).⁹ We find that (3) becomes sig-



nificant when E_{abs} is greater than 35 kJ/mol. However, if $E_{\text{abs}} \leq 135$ kJ/mol (corresponding to a maximum temperature of 1050 K), (3) is too slow to be noticeable during the first 4 μ s, in agreement with thermal rate constants.¹⁰

In order to confirm the validity of the above interpretation, we did some experiments with concentrated IR beams so that maximum temperatures would exceed 1400 K and (3) would be significant during 4 μ s, according to thermal rate constants.¹⁰ Figure 2, which shows results obtained under such conditions, clearly shows (a) disappearance of DHP and (b) formation of acrolein on the 4- μ s time scale. The present work, however, will be concerned primarily with transient UV absorption in the absence of reaction 3.

(9) Garcia, D.; Keehn, P. M. *J. Am. Chem. Soc.* **1978**, *100*, 6111.

(10) Half-lives for the thermal retro-Diels-Alder reaction 3 are 38 s at 700 K, 8.8 ms at 900 K, and 42 μ s at 1100 K, based on data of: Wellington, C. A. *J. Chem. Soc. A* **1969**, 2584.

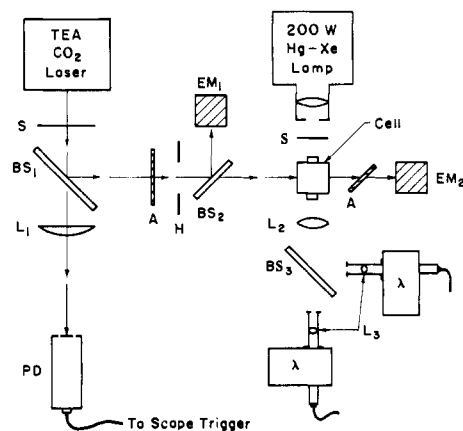

Figure 3. Layout of optical components: S = shutter; BS = beam splitter (1,2 = coated germanium, 3 = quartz); L = lens (1 = germanium, 2 = sapphire, 3 = quartz); A = CaF₂ attenuator; H = plastic plate with circular hole for beam sizing; PD = photon drag detector; EM = energy meter (1 = pyroelectric, 2 = disk calorimeter); λ = monochromator-photomultiplier; cell = No. 316 stainless-steel transverse monitoring cell (length = 2.6 or 0.8 cm; diameter = 2.0 cm).

Experimental Section

Materials. 2,3-Dihydropyran (98%) was obtained from Aldrich Chemical Co. It was purified by fractional distillation. The purity was checked by IR and GC and found to be better than 99%. Prior to use, 2,3-dihydropyran was degassed by at least five freeze-pump-thaw cycles.

Instrumentation. A schematic diagram is shown in Figure 3. The experimental setup combines the pulsed CO₂ laser and energy-measuring system described previously¹¹ with ultraviolet kinetic spectroscopy equipment. The accuracy of E_{abs} was improved to a standard error of 5% by using an Autolab System I computing integrator to integrate the unamplified output of the Scientech energy meter.

The UV kinetic spectroscopy equipment consisted of a 200-W xenon-mercury arc (Canrad-Hanovia No. 901 B 0011) and two monochromators operating in parallel (Jarrell-Ash No. 82-410) with associated photomultipliers and fast storage oscilloscopes. Starting power for the xenon-mercury arc was provided by an Oriol No. 85-12 arc lamp power supply. After a few minutes of warm-up operation, supply current was transferred to a highly regulated Hewlett-Packard No. 6267 DC power supply. When thus stabilized, the UV-vis light output of the xenon-mercury arc was not affected by firing the infrared laser.

A shutter prevented the UV-vis monitoring beam from entering the reaction cell until a few seconds before the IR laser pulse. Control experiments showed however that UV-vis irradiation for as long as 30 min did not induce any significant photochemistry.

Returning to Figure 3, lens L₃ focusses the collimated UV monitoring beam (1/8-in. diameter) onto the entrance slit of the monochromator. Beam splitter BS₃ is a 50 × 50 × 2-mm quartz, 0.5 neutral density filter (Melles Griot No. 03FNQ 085, visible transmittance 31%, reflectance 30-35%). It is mounted vertically at 45° with respect to the monitoring beam but is omitted when dual-wavelength monitoring is not needed.

Two different photomultiplier tubes were used. EMI 9798 QB was more sensitive but slower (electron transit time ~120 ns at 400 V, response time ~12 ns). EMI 9781 B was less sensitive but faster (transit time ~40 ns at 400 V, response time <5 ns). Signal/noise could be improved at the expense of response time by using a 200- Ω termination resistor, which gave response times of 50-60 ns.

The wavelength scale of the monochromator was checked against mercury emission lines. The slit width was adjusted for best compromise between signal/noise and resolution. In most experiments 1-mm slits were used.

In order to determine whether gradients in the gas resulting from infrared absorption and subsequent transport processes and mixing affect UV transmission, we did control experiments in which the monitoring wavelength was >250 nm so that UV absorption is negligible. The oscilloscope traces of UV transmission vs. time were horizontal lines, independent of whether or not the gas absorbed energy from an IR laser pulse.

Laser Pulse Profile. The laser pulse profile was measured by replacing the EM2 meter (Figure 3) with a photon drag detector (Rofin Model 7401). The pulse profile was measured through the evacuated and the

(11) Grunwald, E.; Olszyna, K. J.; Dever, D. F.; Knishkowsky, B. *J. Am. Chem. Soc.* **1977**, *99*, 6515.

gas-filled cells. In most experiments, the photon drag signal was smoothed by a 20-MHz electrical filter, displayed on the screen of a fast storage oscilloscope, and photographed. The photon drag detector was also used as depicted in Figure 3 to trigger the scope on the leading edge of the IR pulse.

Synchronization. Laser pulse profile and photomultiplier output (optical transmission) were measured consecutively, displayed on the same storage screen, and photographed. Precise synchronization was achieved by taking into account the photomultiplier transit time and any difference in instrumental response times.

After the work had been nearly completed, a Biomation Model 8100 waveform recorder became available, permitting improved accuracy. Several experiments were repeated by using this technique. Results were in good agreement with those based on the photographic methodology.

Analytical Data. Reaction cells were filled with gas by using standard vacuum-line techniques. Quantitative analysis as well as product identification was done by IR using a Perkin-Elmer Model 323 spectrophotometer and by GLC using a 5 ft \times 1/4 in. SE 30% column. IR spectra were taken with the gas in the reaction cell, both before and after irradiation.

IR-Induced Reaction.^{1b} When DHP vapor (0.5–2.0 mM) was pulse-irradiated at 1072 cm^{-1} or when SiF_4 -DHP mixtures were pulse-irradiated at 1025 or 1031 cm^{-1} , decomposition of DHP became significant at sufficiently high E_{abs} . The only products found under all conditions were ethylene (E) and acrolein (A). Within 10% experimental error, the molar amounts of E and A were equal to each other and equal to the amounts of DHP that disappeared. Careful searches were made for other products by GLC and by comparison of IR spectra obtained after irradiation with those of authentic mixtures of DHP, E, and A; none were ever found. In some cases O_2 was deliberately added; no new products appeared. Thus (3) is the only significant IR-induced chemical reaction.

For 0.5–2.0 mM DHP vapor irradiated at 1072 cm^{-1} , the fraction (f) decomposed per pulse depends on E_{abs} /mol of DHP but is practically independent of DHP concentration. Representative results are as follows: E_{abs} (f) 81 (0.033), 103 (0.133), 115 (0.242), 135 kJ/mol (0.335).

IR Absorption. Extensive data for IR absorption of DHP at 1072 cm^{-1} and of DHP- SiF_4 mixtures at 1025 and 1031 cm^{-1} are reported in the Ph.D. Thesis of D.G.^{1b} The following summary of results for DHP at 1072 cm^{-1} will suffice at this time. Infrared fluence (dose) D ranged from 0.2 to 2.5 J/cm^2 . E_{abs} ranged from 26 to 250 kJ/mol. DHP concentration ranged from 0.5 to 2.0 mM. E_{abs}/D was practically independent of DHP concentration and

$$E_{\text{abs}}/D = 2.55 \times 10^5 / (1 + 0.803D^{0.603}) \text{ cm}^2 \text{ mol}^{-1}$$

The numerator, $2.55 \times 10^5 \text{ cm}^2 \text{ mol}^{-1}$, is obtained from the IR extinction coefficient $\epsilon = 0.00595 \text{ cm}^{-1} \text{ torr}^{-1}$ measured at 1072 cm^{-1} by conventional spectrometry, recalling that the low-intensity limit of $E_{\text{abs}}/D = 2.303RT\epsilon$.

Normal-Mode Wavenumbers. In order to calculate temperatures reached on IR excitation, normal-mode wavenumbers for DHP were needed. Because a full vibrational analysis has not been published, the 36 normal-mode wavenumbers were obtained the following way: comparison was made with spectra and full vibrational analyses for such model compounds as 1,4-dioxadiene and aliphatic ethers.^{12,13} This led by analogy to a list of predictions, a significant part of which could be compared with observed IR band positions. On substituting our observed wavenumbers for IR active modes to the extent possible, as well as available wavenumbers^{3,4} for ring bending and twisting, the following list was obtained: 3070, 3070, 2970, 2970, 2930, 2870, 2870, 2870, 1650, 1475, 1465, 1450, 1410, 1375, 1335, 1335, 1335, 1260, 1245, 1200, 1150, 1090, 1080, 1030, 940, 925, 900, 845, 755, 735, 510, 470, 440, 305, 280, 180.

Results

Transient Plateau. Figure 1a shows the typical initial behavior of the transient absorption that appears upon IR irradiation of DHP when E_{abs} is in the range 20–120 kJ/mol. We shall now characterize the transient plateau that is reached after about 2 μs and which persists for about 10 μs .

It was found in previous work on $\text{CHClF}_2 + \text{Br}_2$,² in which E_{abs} by CHClF_2 was measured and Br_2 absorption at 436 nm served as a thermometer, that a similar transient plateau is reached after 2–3 μs and that it represents a steady state in which thermal equilibrium is reached at constant volume. Likewise, in previous

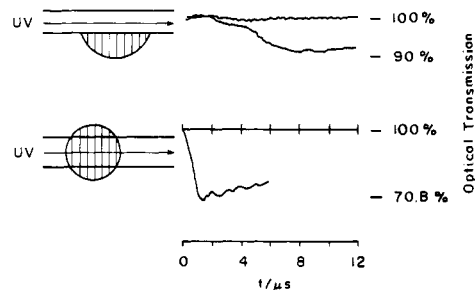

Figure 4. Quiescent period prior to expansion of 16.5 torr (298 K) of DHP irradiated at 1072 cm^{-1} ($E_{\text{abs}} = 250 \text{ kJ/mol}$; $\theta_p > 1400 \text{ K}$): top trace, truncated IR beam; bottom trace, control (using normal experimental procedure). UV monitoring is done at 237 nm.

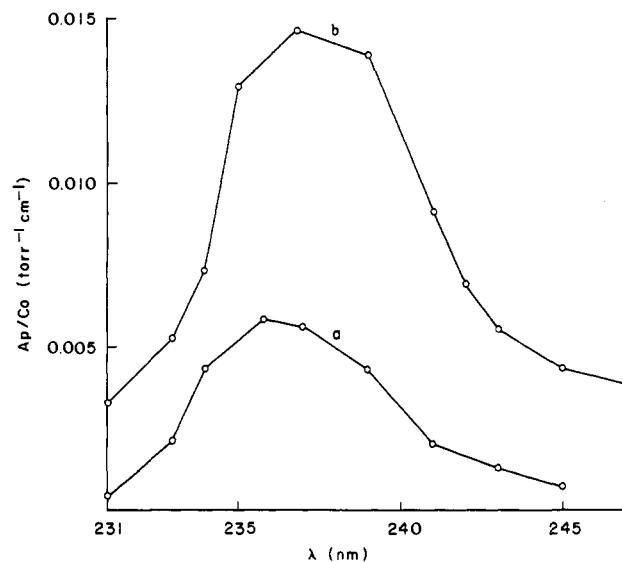

Figure 5. Transient absorption spectra (a) at $\theta_p = 600 \text{ K}$ and (b) at $\theta_p = 1065 \text{ K}$. c_0 is expressed in torr at 298 K.

work on $\text{CBr}_2\text{F}_2 + \text{Ar}$,¹⁴ in which E_{abs} by CBr_2F_2 was measured and absorption by CBr_2F_2 at 258 nm served as a thermometer, interpretation of the transient plateau as a state of thermal equilibrium at constant volume was similarly successful.

In the present case, the same interpretation was tested by direct measurement of gas expansion from the IR-irradiated zone into the rest of the cell. In the experiment shown in Figure 4a, the IR beam is truncated at the edge of the UV probe beam, as shown on the left in the figure, and the time required for UV absorbing species to invade the probe beam is measured. Figure 4b shows the corresponding control experiment without IR-beam truncation. Note the expanded vertical scale in Figure 4a. The IR beam is small (1-cm diameter) and E_{abs} is high (250 kJ/mol) to provide a severe test. Gas expansion becomes significant after 4 μs .

It seems reasonable to assume that for larger IR beams (1.7-cm diameter) and smaller E_{abs} (20–120 kJ/mol) used in the following, the transient plateau consistently represents a state of transient thermal equilibrium at constant volume.¹⁵ Thus the temperature reached by the irradiated gas at the transient plateau, θ_p , can be calculated from the initial temperature (298 K) and E_{abs} , using normal mode frequencies listed earlier and familiar statistical thermodynamic formulas for constant-volume heating.¹⁶

Properties of the Transient Species. Let $c_0 = \text{total (i.e., formal) concentration of DHP}$, $\text{OD} = \text{optical density}$, $L = \text{UV path length}$, and $\text{OD}/L = A = \text{absorbance}$. Numerous measurements in which

(14) Unpublished results by N. C. Westby, Brandeis University.

(15) Applications of the Lambert-Salter rule to DHP, a hydrogenic molecule with lowest normal-mode frequency of 180 cm^{-1} , lead to the prediction that V - T relaxation times are <40–10 ns at pressures of 8–32 torr. Lambert, J. D.; Salter, R. *Proc. R. Soc. London, Ser. A* 1959, 253, 277.

(16) *Natl. Stand. Ref. Data Ser. (U.S., Natl. Bur. Stand.)* 1971, NBSRDA-NBS 37, pp 9–10.

(12) Connett, J. E.; Creighton, J. A.; Green, J. H. S.; Kynaston, W. *Spectrochim. Acta* 1967, 22, 1859.

(13) Snyder, R. G.; Zerbi, G. *Spectrochim. Acta, Ser. A* 1967, 23A, 391.

c_0 ranged from 0.5 to 2.0 mM and plateau temperatures Θ_p ranged from 570 to 1065 K showed that, at constant Θ_p , absorbance A_p at the transient plateau is directly proportional to c_0 . Thus the transient absorbing species is in 1:1 equilibrium with DHP; that is, it is a subspecies or isomer of the formal DHP species.

Measurements of A_p/c_0 at constant Θ_p yielded transient absorption spectra, shown in Figure 5. Half-widths (fwhm) are 1200 cm^{-1} at 600 K and 1390 cm^{-1} at 1065 K. λ_{max} is remarkably insensitive to Θ_p , being 236 nm at 600 K and 237 nm at 1065 K. Statistically, the 1-nm difference is only marginally significant.

Let c_B and ϵ denote concentration and molar extinction coefficient, respectively, of the transient species. Let $K = c_B/(c_0 - c_B = A_p/(\epsilon c_0 - A_p))$. K and ϵ are functions of temperature.

To represent $K(\Theta_p)$, we note that the transient species is a subspecies (probably the boat form) of DHP, and therefore $\Delta S^\circ \approx 0$.¹⁷ This leads to the approximation (4).

$$\ln K = \ln [A_p/(\epsilon c_0 - A_p)] = -\Delta E^\circ / R\Theta_p \quad (4)$$

For best accuracy, we limit data fitting to λ_{max} . (A constant wavelength of 236.8 nm was used throughout.) We assume that $\epsilon_{\text{max}}(\Theta_p)$ varies inversely with the band half-width, which is known at 600 and 1065 K (Figure 5). Wieland and co-workers¹⁸ have shown, for substrates ranging from Cl_2 to biphenyl, that when λ_{max} is practically independent of temperature, ϵ_{max} is represented quite accurately by (5), where Θ_p is used in place of temperature. B is a specific parameter. In the present case, $B = 850$ K for the transient absorption band, based on the half-widths at 600 and 1065 K. Thus, with use of (4) and (5), there are two unknown parameters, $\epsilon_{\text{max}}(0)$ and ΔE° .

$$\epsilon_{\text{max}}(\Theta_p) = \epsilon_{\text{max}}(0)[\tanh(B/\Theta_p)]^{1/2} \quad (5)$$

A nonlinear least-squares program was written to compute $\epsilon_{\text{max}}(0)$ and ΔE° from experimental data (A_p , Θ_p). On the basis of 20 data sets, in which Θ_p varied from 570 to 1065 K, $\epsilon_{\text{max}}(0) = 2.30 \times 10^3 \text{ M}^{-1} \text{ cm}^{-1}$, and $\Delta E^\circ = 15.2 \text{ kJ/mol}$. $\ln K = -1828/\Theta_p$. The standard error of fit of A_p is 6%.

On the basis of calculations involving possible alternatives to (5) as well as data at 247 nm, we estimate that ΔE° is accurate to 2 kJ/mol.

Identification of the Transient Species. Formally, the transient absorption band is a "hot band". However, if the vibrational levels of the electronic ground state from which the "hot" transition originates are separated from those involved in the room-temperature transition by a potential barrier, it is appropriate to describe the "hot" absorption as being due to an isomeric species. The latter description seems indicated because (1) the "hot band" is well separated from the nearest room-temperature UV absorption band, (2) it is very strong, (3) λ_{max} for the "hot band" is approximately constant, and (4) a simple exponential relation (eq 4) fits well, over a 500 °C temperature range. These facts are not easily reconciled with the hypothesis that the "hot band" is due to electronic transition originating from $V = 1$ vibrationally excited states of the half-chair form.

A transient isomer may be an isomeric substrate or a conformational isomer to the half-chair form. Concerning the latter, a potential function for ring twisting and ring bending has been obtained by fitting high-resolution far-IR and Raman spectral data.^{3,4} The function indicates the existence of two stable ring conformations, a half-chair and a boat, separated by a barrier.¹⁹ There is a close similarity between this function and an analogously derived potential function for cyclohexene,⁴ which implies similar conformational energetics. Available data for the two substances are listed in Table I. There is an evident similarity, with energy quantities for cyclohexene tending to be somewhat smaller than

Table I. Energetics of Half-Chair to Boat Interconversion of 2,3-Dihydropyran (kJ/mol)

	2,3-dihydropyran cyclohexene	
potential barrier (half-chair to boat)	29, ^a 32 ^b	31.5 ^b
activation energy (half-chair to mirror image)	28 ^{c,h}	22 ^{d,h}
ΔE° (half-chair to boat)	(15.2) ^e	11.3, ^f 14 ^g

^a Far-IR spectroscopy.³ ^b Raman spectroscopy.⁴ ^c DNMR.⁶ ^d DNMR.²⁰ ^e Half-chair to transient species, present work. ^f Heat capacity.²¹ ^g Ultrasonics.²² ^h Preexponential factor = $1.0 \times 10^{13} \text{ s}^{-1}$.

Table II. Absorption of Radiant Energy by 18 torr 2,3-Dihydropyran in a 2.6-cm Cell, from a Laser Pulse at 1072 cm^{-1}

time, ns	I_0^a	I^b	I/I_0
110	(1557)	(918)	
140	1017	482	0.474
160	696	370	0.532
180	611	312	0.511
200	446	192	0.431
240	212	108	0.509
260	194	87	0.449
310	108	44	0.407
360	82	36	0.439
410	71	30	0.423
510	65	26	0.408
610	66	30	0.458
760	61	28	0.455
960	42	19	0.452
1160	34	14	0.412
1360	25	11	0.440
1560	20	8	0.400

^a Empty cell. ^b Gas-filled cell, in the same arbitrary units.

those of DHP. The value of ΔE° for formation of the transient species fits nicely into this pattern.

In order for the transient isomer to be an isomeric substance $\text{C}_5\text{H}_8\text{O}$, we must meet the following conditions: because of the high speed of appearance of the transient absorption, the activation barrier for formation from DHP must be low. Formation must be reversible, $\Delta E^\circ \approx 15 \text{ kJ/mol}$. The isomeric substance must be stable to decomposition or decompose to C_2H_4 and acrolein (which are the only detected products) and be unreactive toward O_2 , even at high E_{abs} .

We have considered cyclic, bicyclic, open-chain, and biradical species $\text{C}_5\text{H}_8\text{O}$. None of them fits. Thus, in all probability, the transient species is the boat form of DHP.

Kinetics of Transient Species Formation. The suggestion that the transient species is the boat form of DHP is consistent also with the following kinetic measurements, which indicate a relaxation time for equilibration which is too short to be measured with our equipment. It will be shown that this is expected for (1).

Because the IR pulse width is *not* small on the time scale on which the transient absorption develops, we measured absorbed intensity as a function of time, deduced the time evolution of E_{abs} , and compared the latter with the time evolution of optical density.

Table II compares transmitted intensity through (i) an empty cell [$I_0(t)$] and (ii) the same cell, gas-filled [$I(t)$], using essentially the same IR pulses. In ii, approximately 50% of the radiation is absorbed by the gas. Measurements of $I(t)/I_0(t)$ became of useful accuracy at or near the pulse peak, which occurred about 60 ns after the beginning of significant IR radiation. The units of I_0 and I are arbitrary, as is the chosen zero time, except that the latter is common to both measurements and precedes the start of the laser pulse.

$I_0(t)/I(t)$ is seen to be approximately constant over a 50-fold variation of intensity. The standard deviation is 9%. Other

(17) Omission of this assumption gave a least-squares estimate of $\Delta S^\circ \approx -2 \text{ J/(mol K)}$.

(18) Herczog, A.; Wieland, K. *Helv. Phys. Acta* **1948**, *21*, 436. Sulzer, P.; Wieland, K. *Ibid.* **1952**, *25*, 653.

(19) Calculations done by Dr. W. J. Hehre using the 4-31G program and by Mr. G. Graham using the PRDDO program confirmed the half-chair as a stable ring conformation.

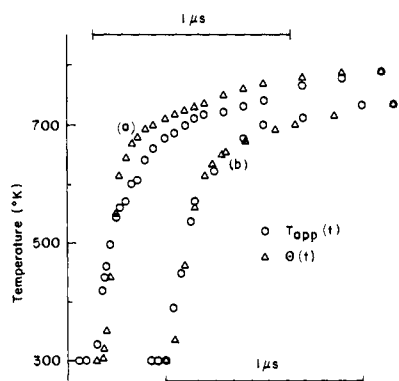

Figure 6. Plots of $\Theta(t)$ and $T_{app}(t)$ vs. time: (a) 25.0 torr of DHP, $E_{abs} = 76.6$ kJ/mol, $\Theta_p = 790$ K; (b) 13.2 torr of DHP, $E_{abs} = 71.7$ kJ/mol, $\Theta_p = 766$ K. The following photomultipliers were used to measure optical transmission at 237 nm: (a) EMI 9781 b, (b) EMI 9798B.

experiments in which DHP concentration, peak intensity, and pulse profile were varied gave similar results. In view of this, it seemed justified to treat the "absorption coefficient" as a constant throughout the given pulse.

Let $E_{abs} = E_{abs}^\infty$ = total radiant energy absorbed per mole of DHP from the given pulse, and $E_{abs}(t)$ = radiant energy absorbed at time t . For constant absorption coefficient it follows that

$$\frac{E_{abs}(t)}{E_{abs}^\infty} = \frac{\int_0^t (I_0 - I) dt}{\int_0^\infty (I_0 - I) dt} = \frac{\int_0^t I_0 dt}{\int_0^\infty I_0 dt} \quad (6)$$

When $E_{abs}(t)$ and transient OD(t) are plotted on a common time scale, the two curves are similar but show small differences. However, at least part of any differences could result from the fact that the two variables are not linearly related. In particular, OD(t) does not become measurable until the temperature exceeds 375 K. To probe for real differences between absorption of energy and transient-species formation, it is necessary to express the two phenomena in consistent units.

We shall introduce two functions with the dimensions of temperature, one derived from $E_{abs}(t)$ and the other from OD(t), as follows.

The quasi-thermal equilibrium temperature $\Theta(t)$ is calculated from $E_{abs}(t)$ on the assumption that statistical equilibrium exists in the irradiated volume at the given time t . Thus $\Theta(t)$ is calculated from $E_{abs}(t)$ by using the same statistical thermodynamic equations (at constant volume) that one uses to calculate transient-plateau temperature Θ_p from E_{abs}^∞ .

The quasi-chemical equilibrium temperature T_{app} (also called apparent temperature) is calculated from OD(t) on the assumption that chemical equilibrium between transient species and half-chair DHP exists in the irradiated volume at the given time t . With use of basically eq 4 and 5, $T_{app}(t)$ is calculated from OD(t)/ Lc_0 , by using previously established values for ΔE° , $\epsilon_{max}(0)$, and B , via (4') and (5').

$$\frac{\Delta E^\circ}{RT_{app}(t)} = \ln \left(\frac{\epsilon_{max} c_0 L}{OD(t)} - 1 \right) \quad (4')$$

$$\epsilon_{max} = \epsilon_{max}(0) [\tanh(B/T_{app}(t))]^{1/2} \quad (5')$$

In view of the stated definitions, a significant difference between $\Theta(t)$ and $T_{app}(t)$ indicates that attainment of either thermal or

chemical equilibrium, or of both, is measurably slow.

Figure 6 shows representative data plotted in the format $\Theta(t)$, $T_{app}(t)$. The time evolutions of the two functions are very similar, especially during the steep initial portions, and any difference between them would seem to be <50 ns.

Granting that relaxation times for attainment of thermal equilibrium are <50 ns,¹⁵ we wish to consider whether the assumed half-chair to boat interconversion of DHP is expected to be this fast. At thermal equilibrium, the rate constant k_r for relaxation to chemical equilibrium in (1) is given by $k_r = k_1 + k_{-1}$. Furthermore, $k_1/k_{-1} = K$, the equilibrium constant, whose value is known according to (4). A direct value can be obtained for k_1 because $k_1 \approx k_2$ for the interconversion of the mirror-image conformations of the half-chair form (eq 2), as explained convincingly for the analogous process of cyclohexene.^{20,23} k_2 has been measured for DHP by low-temperature dynamic NMR (120–150 K) in vinyl chloride solvent. The assignment $k_2 \approx k_1$ is supported by the quality of agreement (Table I) between the activation energy for (2) and the potential barrier for the forward process in (1). On this basis it is found that $k_r = 5.7 \times 10^{10} \text{ s}^{-1}$ at 298 K and $2.0 \times 10^{12} \text{ s}^{-1}$ at 900 K. Errors in k_r due to the need to extrapolate the low-temperature NMR data to high temperatures, and due to the use of liquid-phase data obtained in a virtually inert solvent rather than gas-phase data, are not likely to exceed 1 or 2 orders of magnitude for this simple conformational isomerization. Thus the hypothesis of half-chair to boat interconversion is consistent with the high observed chemical relaxation rate.

Discussion

Because of thermal instability of 2,3-dihydropyran, the half-chair to boat equilibrium must be measured in a very short time, and the present method of IR flash-heating coupled with kinetic spectroscopy provides a way of doing it. Viewed as a general method, there are limitations however. First, owing to imprecision (~5%) in the measurement of E_{abs} , a wide temperature range must be used in order to secure results of useful accuracy. This limits applicability to equilibria with ΔE° of relatively small magnitudes, perhaps <50 kJ/mol.

Second, there may be error due to inhomogeneity of fluence across the laser beam. A pragmatic measure of inhomogeneity was proposed previously.¹¹ At 1072 cm^{-1} used in the present study, this measure amounts to a standard deviation of fluence of 10–15%. Systematic error ensues because the UV probe beam samples only one-third of the IR-irradiated cross section of gas. We estimate however that at transient equilibrium, the average temperature in the region sampled by the probe beam differs from Θ_p by less than 5–8% of the T jump.

A distinct advantage of the method is that it permits the convenient measurement of UV absorption spectra up to very high temperatures, even for labile substrates. In the present case the UV absorption spectrum of the boat form of DHP (Figure 5) has noteworthy features. In particular, λ_{max} is considerably longer than λ_{max} for the first UV absorption band of the half-chair form,^{7,8} and it is quite insensitive to temperature.

(20) Anet, F. A. L.; Haq, H. Z. *J. Am. Chem. Soc.* **1965**, *87*, 3147.

(21) Beckett, C. W.; Freeman, N. K.; Pitzer, K. S. *J. Am. Chem. Soc.* **1948**, *70*, 4227.

(22) Pedinoff, M. E. Ph.D. Thesis, University of California, Los Angeles, 1959.

(23) The analogy is not exact because of the lower molecular symmetry of DHP. However, the potential energy function which fits the ring-bending and ring-twisting energy levels of DHP has precisely the same mathematical form and even symmetry as that which fits the corresponding energy levels of cyclohexene.